

# HOMOLOGATION AND TECHNICAL SPECIFICATION UPDATE BULLETIN

HOMOLOGATION	PRD GALAXY	HOMOLOGATION NO.	100H
BULLETIN NO.	100H-2	BULLETIN DATE	24 APRIL 2017
SUBJECT	PRD Galaxy Permitted Carburetors		

The information and specifications contained in this Homologation and Technical Specification Update Bulletin are to be read in conjunction with and form part of the homologation detailed herein.

## Homologation Document Reference Page 24-25 - PRD GALAXY CARBURETTOR

### Background

SGK are introducing the Tillotson HW-30A PRD carburettor as standard equipment on all new PRD Galaxy Engines.

SGK advise that there is no performance advantage in using the Tillotson HW-30A PRD carburettor when compared with the originally supplied Ibea PRD L9 carburettor.

The Tillotson HW30A PRD has been in used in Europe for several years and is proven to be a reliable and easy carburettor to use.

The change in carburettor offers simplified adjustment, economical spare parts and brings the carburettor into line with PRD engines that are sold internationally.

The use of the HW30A Carburettor with the Galaxy engine brings Australian competition into line with other countries that are using the PRD Galaxy engine.

### Details Of Permitted Carburetors

1. Both the Tillotson HW30A PRD Carburettor and the Ibea PRD L9 carburetors are eligible for competition.
  - Transition to the Tillotson HW30A PRD Carburettor is not compulsory.
2. Tillotson HW30A PRD Carburettor and Ibea PRD L9 will use the same KA Carburettor checking tools.





PHOTO OF CARBURETTOR	
ORIGINAL IBEA PRD L9	NEW - TILLOTSON HW-30A PRD
	

PHOTO OF CARBURETTOR	
ORIGINAL CARBURETTOR - IBEA PRD L9	NEW - TILLOTSON HW - 30A PRD
	

DRAWING OF IBEA PRD L9	DRAWING OF TILLOTSON HW-30A PRD
	

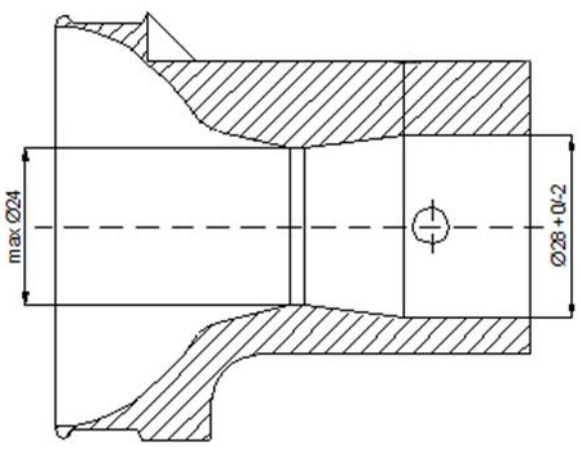
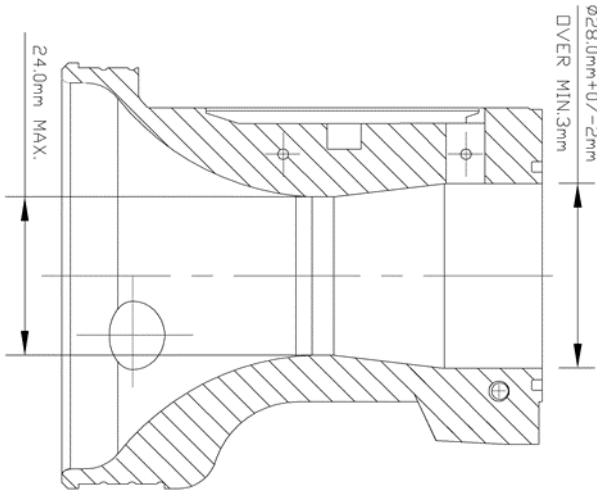

Les Allen - National Technical Director

24 April 2017