



PRD FIREBALL 125

TECHNICAL SPECIFICATIONS



VERSION 1 / 2012
UPDATED JANUARY 1st, 2012



PRD FIREBALL 125 ENGINE TECHNICAL SPECIFICATIONS

Preamble:

The following are the Technical Specifications for the PRD FIREBALL 125 engine, as approved by the Australian Karting Association.

This engine is approved for use in the following classes.

- Junior Performance
- Tag 125
- Restricted 125
- Open Performance

Unless otherwise specified, the engines must be original in all their components according to the PRD FIREBALL 125 drawings.

Any removal, addition or polishing of material is strictly forbidden.

Sandblasting, glass bead blasting, peening, acid etching, spark eroding and/or any other method of metal removal or displacement is not allowed.

The use of thermal barrier coatings / ceramic coatings on or in the engine / engine components and on or in exhaust components is prohibited.

The use of anti friction coatings on or in the engine / engine components is prohibited. OEM pistons are exempt.

ANY ALTERATIONS / MODIFICATIONS ARE STRICTLY PROHIBITED EXCEPT AS SPECIFICALLY AUTHORISED WITHIN THESE SPECIFICATIONS.

IF THESE SPECIFICATIONS DO NOT SAY YOU CAN MAKE A MODIFICATION, THEN YOU CANNOT.

PRD 1.01

Max Bore size	54.28
Max Stroke	54.004
CCV	10.0cc min
Carburetor	Tillotson 360 A, No modifications or ENZO 24mm
Venturi	0.95 inch
Carburetor Bore	1.065 inch
Exhaust Height	174 deg max
Exhaust System	OEM Header only, OEM Straight PRD9037/95A or Bubble PRD9037/EVO99A Muffler No Modifications to either The addition of Exhaust Gas Temperature fitting is acceptable. Measurements: A: 100mm, B: 54mm, C: 3mm, D: 170mm, E: 315mm, F: 170mm, G: 21mm, H: 135mm, I: 455mm ±1.00 mm on all Measurements

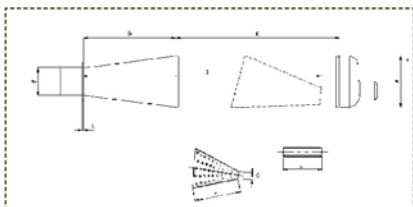

Straight – PRD 9037/95A



PRD FIREBALL 125 ENGINE TECHNICAL SPECIFICATIONS

Ignition Parts	PRD or PRD/Opama All must be OEM unless specified non-tech or otherwise. PRD Easy Start Ignition System (Part #PRD0073ES19) Addendum #25, 2011.
Coatings	No coatings to engine components other than standard are permitted.
Non-Tech Items	Switches, Battery, Fasteners, spark plugs, Engine Sprocket, Water Hoses, Water Pump, Axle Pulley & O Rings. No alterations from original manufacturers specification is permitted to fit a non tech item.
Cylinder	Must be OEM, All ports and passages are cast finish except some pre-existing factory removal of flashing. No modifications to the ports accepted.

Chord reading	
B	65.3mm ± 0.10
C1=	26mm ± 0.10
C3	29.4mm ± 0.10
Angular reading by inserting a 0.2mm gauge	
E	174 dea max
F	127 dea max
G	128 dea max

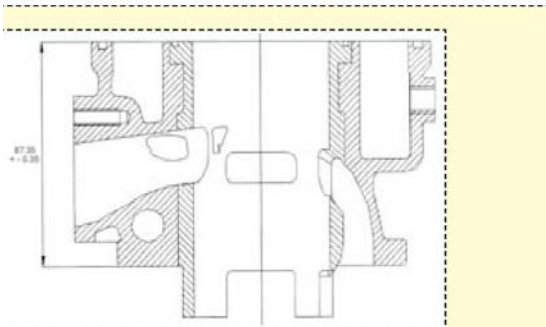
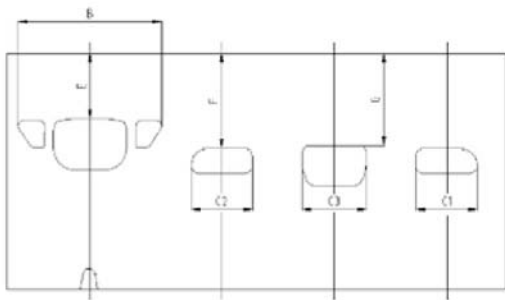

PRD 1.02 Cylinder Head

Must be OEM, Modification to the cylinder head to achieve min cc's is acceptable.



PRD FIREBALL 125 ENGINE TECHNICAL SPECIFICATIONS

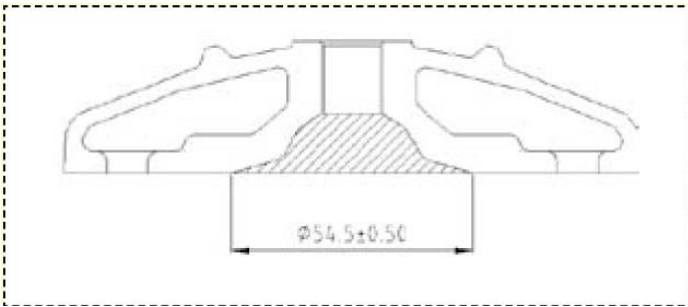

PRD 1.03 Crankcase
Must be OEM with no modifications.

PRD 1.04 Crankshaft Must be OEM with no modifications.

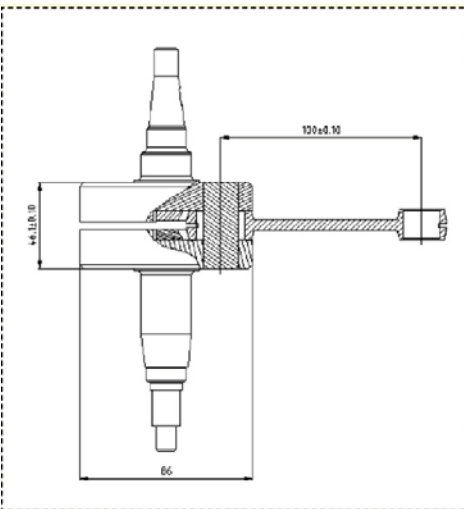

PRD 1.05 Conrod Must Be OEM, PRD Medium Weight 120grams +/- 2, No Modifications

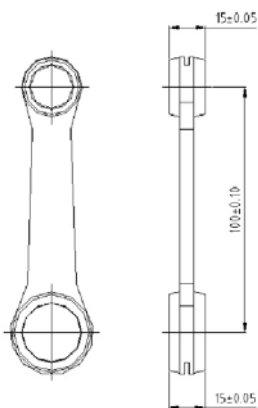

PRD 1.06 Piston Must be OEM, coated and uncoated pistons allowed as supplied by the manufacturer.
No Modifications



PRD FIREBALL 125 ENGINE TECHNICAL SPECIFICATIONS

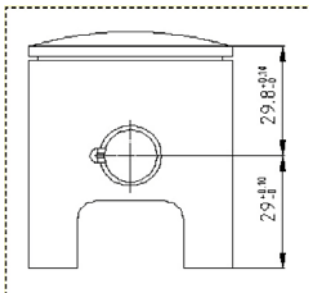

PRD 1.07 Piston Pin

Must be OEM, 10mm ID & 11mm ID PRD Piston Pins Accepted. 10mm ID piston pin to be fazed out by 01/01/08

PRD 1.08 Clutch

PRD Three Shoe Clutch or PRD/Horstman FX-100 Clutch

PRD Light, Medium & Heavy Shoes acceptable.

PRD Steel Clutch Kit (Clutch Centre PRD0080FD) Addendum #25, 2011.

(Clutch Drum PRD0094CA)

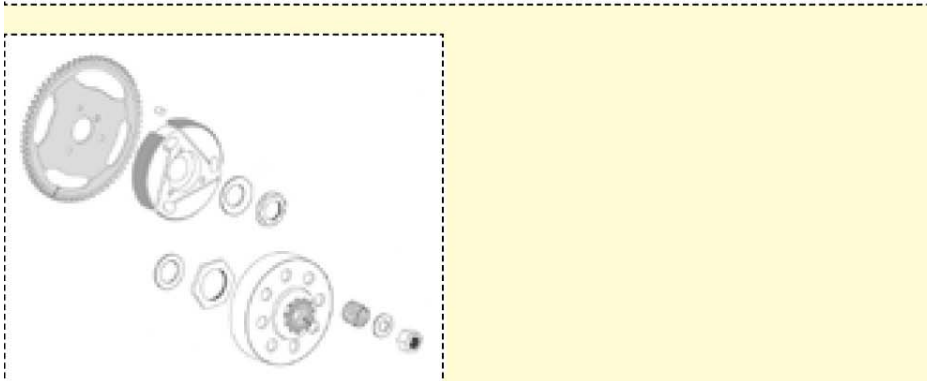
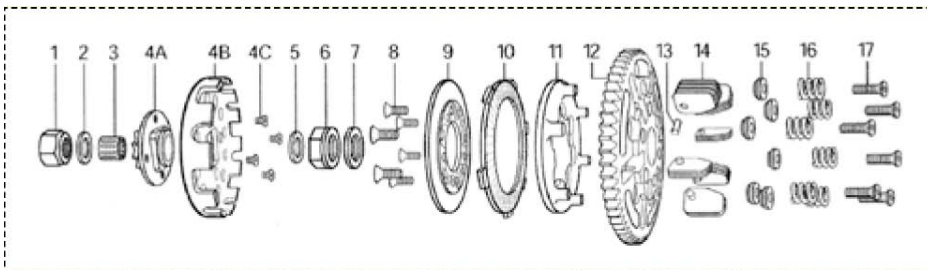

PRD 1.09 Radiator

OEM Recommended. Core and tank size must be with in 5mm of the drawing. Curved Radiators not allowed.

