



UPDATE 5 20th December 2011

Australian Karting Association

Technical Document TDKF3(2012)

Technical Regulations for CIK PRO JUNIOR KF3 Class

*** The only engine eligible for use in this category is the Vortex KF3 engine supplied by the AKA.**

43.4 KF3 Class Tyres

Dry Tyres;

** Tyres: 5" Dunlop DEH, 6 tyres per meeting for racing and time trial these shall be known as the control tyres.*

3 Front tyres

3 Rear tyres plus

Tyre use at the discretion of the competitor

Competitors can only have 2 front and 2 rear tyres in their possession at any time.

For the purpose of practise and carburetion the control tyres are not mandatory for use, but may be used at the discretion of the competitor.

Wet Tyres:

Dunlop KT11 W11 CIK

4 front tyres plus 1 spare.

4 rear tyres plus 1 spare.

For a meeting that is declared wet from it's commencement, tyres are to be used as follows;

1 set of tyres to be fitted and used at the commencement of time trials and must remain in use throughout the heats.

2nd set of tyres must be fitted and used at the commencement of the first final / prefinal and remain in use until the conclusion of the last final.

Should the meeting be declared wet at any time after time trials, use of wet tyres is at the discretion of the competitor.

For the purpose of practise and carburation the control tyres are not mandatory for use, but may be used at the discretion of the competitor.

Replacement Tyres:

In case a slick tyre is punctured during time trials, a replacement may be used providing the damaged / punctured tyre is reported to the Technical Officer prior to leaving parc ferme / in-grid area. The replacement tyre must be used on the non load side of the kart and must be verified by the Technical Officer prior to the next section of the event. For the second final, if a new replacement tyre is required due to damage or faulty manufacture, the competitor must start at the rear of the field. The competitor may elect to use a used tyre from their allotted tyres, which is in

similar condition to those remaining on the kart as a replacement for the second final, which would allow the competitor to start from their correct grid position. The condition of the used replacement tyre must be verified and approved by the Technical Officer and the chief steward must be notified prior to the commencement of the second final.

43.5 Wheels: as per CIK Technical Regulations 2.22.1 – Rims

The use of rims complying with the CIK-FIA technical drawing No. 4 is compulsory:

- 1. Diameter of coupling for tyres: for 5 inch rims: 126.2 mm with a tolerance of +/-1.2 for the circumference with the hump and a tolerance of -1 for the diameter of rims with screws.*
- 2. Width of the tyre housing: 10 mm minimum.*
- 3. External diameter for 5 inch rims: 136.2 mm minimum.*
- 4. Radius to facilitate the balance of the tyre in its housing: 8 mm.*
- 5. Maximum pressure for assembly: 4 Bar.*
- 6. Tyre burst resistance test with fluid at an 8 Bar pressure.*
- 7. This rim must be manufactured in accordance with the appended technical drawing No. 8. The diameter of the rim must be 5" maximum.*
- 9. The front and rear wheels must have some form of bead retention with 3 pegs/ screws minimum in the outside rim.*

43.6 Homologated Engines and Modifications:

*** Modifications**

*Any modification is forbidden if it is not explicitly authorised by an article of these Regulations, or for safety reasons decided by the CIK-FIA or AKA. By modification it is meant, any operations likely to change the initial aspect, the dimensions, the drawings or the photographs of an original homologated part represented on the Homologation Form. **Maximum No. of engines 2 only.***

** Power valve is strictly forbidden*

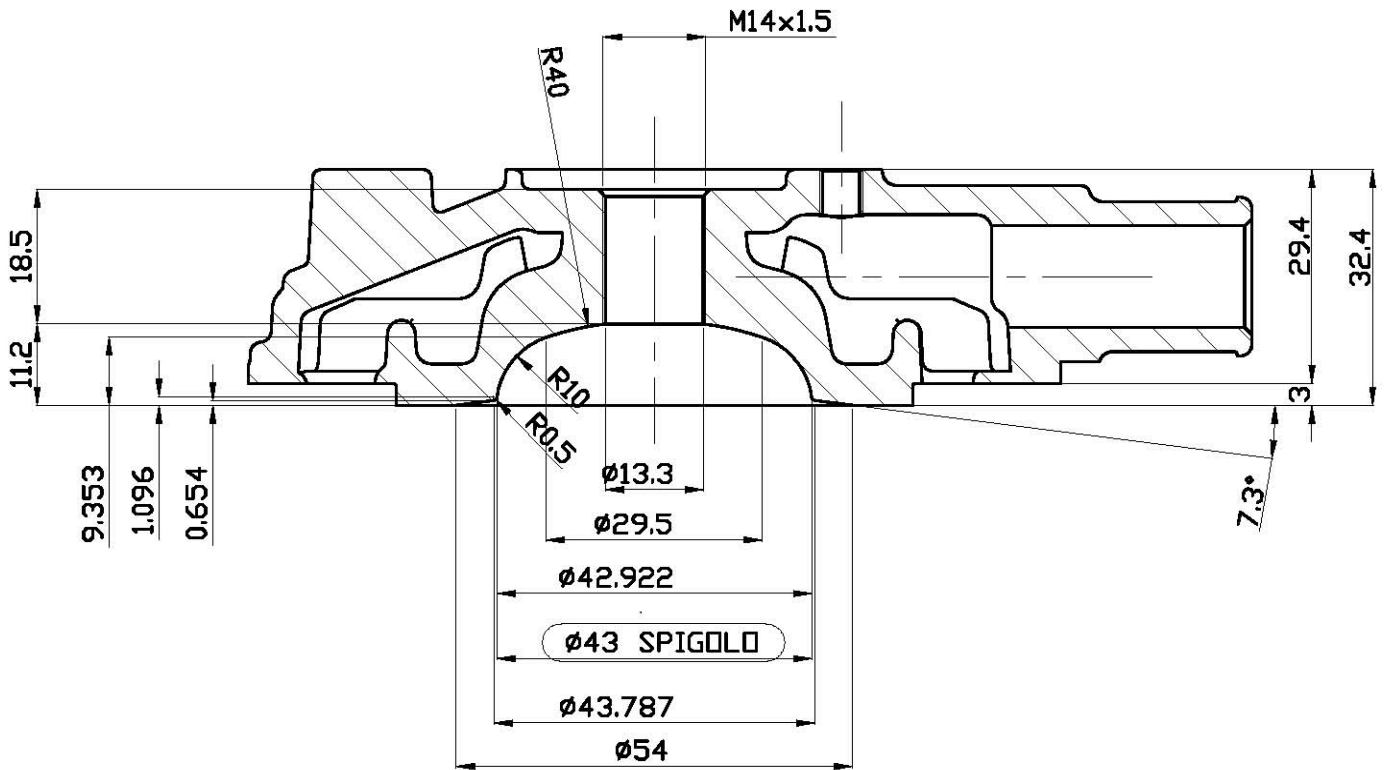

V. Scarpone, 39
I-27100 PAVIA

PAGINA 1 DI 1

EMISSIONE

SOSTITUISCE:

DATA: 17/02/11

DENOMINAZIONE: CUPOLA KF3

GREZZO:

MATERIALE: ALLUMINIO

TRATTAM.:

TOLL.GEN.
ALBERI h11 - FORI H11
RESTO Js11 - ANG. ±0.2°

STATO:

CARATT.MECC.:

RAGGI: R=0.4

SMUSSI: 0.5x45°

TRATT.SUPERF.:

DEL PRESENTE DISEGNO SONO
VIETATE LA VISIONE, LA CESSIONE
E LA COPIA, ANCHE PARZIALE, SENZA
IL NOSTRO CONSENSO SCRITTO.

DIS. Casanova

QUANTITA': 1

CONTR.

SCALA: 1.000



N.DIS.:

* Cylinder head may be repaired / modified to a maximum tolerance of -0.2mm of the dimension on the homologation form. The Combustion chamber minimum volume of 14 cc, measured in accordance with the AKA cc measuring method.

* Cylinder may be modified **except** in the following areas, Volume of transfer ducts, exhaust duct length, internal profile of the exhaust duct outlet, maximum ports chord width and lower gasket plane of the cylinder according to the Homologation Form. These elements cannot be modified or altered in any way or method and are control surfaces and areas. The upper cylinder plane may be repaired **but must comply with all dimensions contained within** the homologation form. For clarity the cylinder ports and passages cannot be modified in any way, and must conform to homologation doc

* Engine rpm limited to maximum 14,000 rpm. Homologated ignition system must be used. The engine ECU program / software cannot be altered or modified.

*On decision of the Stewards or Technical Official, they shall be authorised to interchange any part or all of the Entrants' ignition systems for the system supplied as original equipment at their discretion for the purpose of checking conformity.

* KF3 homologated butterfly carburettor with a maximum diameter of 20 mm, comprising two set screws; it must remain strictly original. It must comply with the Homologation Form and the tooling deposited by the Manufacturer for the control of the shape of the inlet duct.

Any form of spacer between the carburettor and the manifold other than a gasket is strictly forbidden.

20mm control carburettor as supplied with, Tryton , Model KF3VAMEC CIK/FIA n 26/C/15

****The homologated exhaust must be used and cannot be altered, the exhaust spacer length is free to a Maximum of 20mm OEM spacers must be used without modification and 1 gasket per face of the spacer only is permissible.**

* Homologated reed block assembly must be used.

* Clutch according to CIK technical drawings No. 15 & 16. - minimum weight (complete clutch with starter ring and engine sprocket) according to the engine Homologation Form.

* The engine clutch must be triggered at 3,000 rpm maximum and make the kart with the Driver on board move forward; it must be in direct drive (and 100% engaged) at 5,000 rpm maximum under all circumstances.

43.7 Weights:

* Total minimum weight: 145 kg (Driver included).

43.8 Chassis: CIK homologated or AKA homologated or registered.

As per CIK regulations, Lateral bodywork (i.e. side pods,) Nassau panel, and front fairings are obligatory. **The green plate holder may choose to run the No.1 or a number of their choosing.**

43.9 Brakes:

Front brakes are forbidden.

Rear Brake must comply with the relevant CIK Homologation or AKA registration.

43.10 Radiator:

The only permissible radiator shall be the Style, type and size as supplied with the engine.

43.11 Air Box (Inlet Silencer):

The airboxs for this class shall be the KG P.No.FA006AG with 23mm ram tubes only.

and the alternate airboxs with maximum 23mm ram tubes only all other dimensions as per the following technical drawings.

43.12 Rear Bumper

*The plastic rear bumper **is mandatory and must comply with the CIK regulations***

